



KILEWS BRUSHLESS ELECTRIC SCREWDRIVER WARRANTY CARD

TERMS & CONDITIONS

- The "Company" refers to Kilews. Free replacement of spare parts under normal usage except : A) bit, B) spring, C) housing, D) cord, E) pilot rod, F) ceramic rod, G) consumables
※ Please refer to the part assembly drawing. (The example is push start type.)
- The warranty period of the motor is 3 years based on 8 normal working hours per day. The warranty period of the motor is 2 years based on unlimited working hours per day. The warranty of the whole screwdriver is 1 year based on unlimited working hours per day.
- The warranty will be null and void if:
 - The product has been damaged due to misuse, abnormal operation, negligence, accident, a natural or man-made disaster.
 - It has been modified, altered and/or repaired by unauthorized person.
 - The serial number or the warranty card has been modified, effaced and/or removed.
 - The Company was not promptly informed of any change of address or the ownership of the product(s).
 - Failing to use genuine parts that sold or recommended by the Company.
- The Company will not be liable for any direct or indirect loss arising from breakdown of the product(s).
- Under this warranty, the Company only provides service during normal business hours. Unavoidable emergency service may be requested outside normal business hours, such service, if available, will be provided and charged per call.
- The Warranty cannot be allowed to transfer without the consent of the Company.
- Please save your original Warranty Card. Send a copy of your warranty card and invoice to our maintenance center for inspection during each service.

KILEWS WEST USA INC MAINTENANCE CENTER :

USA: 6945 NW LTC PKWY, Port Saint Lucie, Florida 34986
 TEL: +772-293-0071
 FAX: +772-465-4368
 Email: sales@kilewest.com
 Web: http://www.kilewest.com

Place label here

Customer's Name : _____

Telephone : _____

Address : _____

Date of Purchase : _____

Distributor : _____

Brushless Electric Screwdriver Part Assembly Drawing

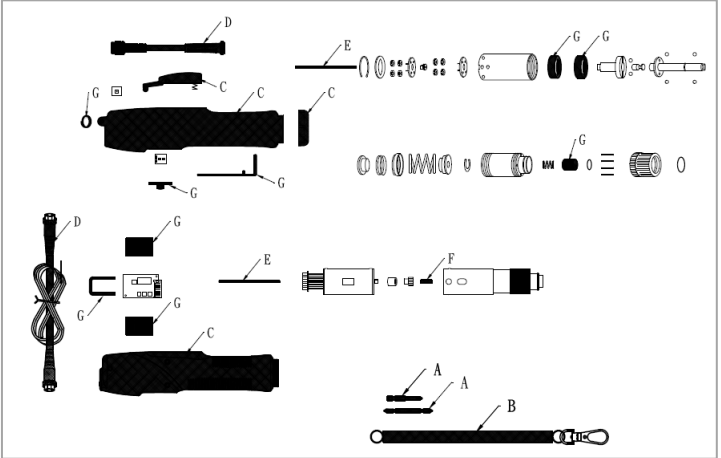

TB TBN Series Brushless Electric Screwdriver Part Assembly Drawing

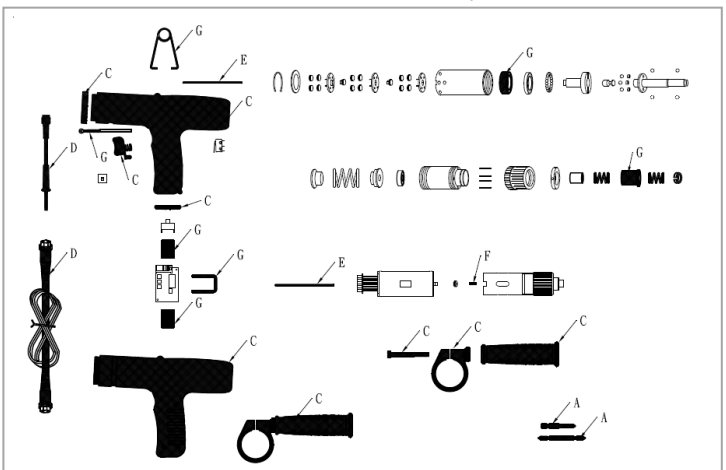

WARRANTY CONDITIONS

1. Purchases of Kilews Brushless Electric Screwdrivers shall be covered by the service warranty. Any damage to the products arising from shipping/handling of products by the buyer shall not be included in the warranty, either by the Company or its distributors. Any such damage incurred during self-handled shipping shall be repaired with the buyer responsible for all parts and repair costs.
2. Malfunction of products used under normal conditions shall be repaired fully at the Company's expense during the service warranty period. However, if the said products are abroad for use in overseas factories, the Company's local branches or distributors shall charge basic repair fees. Within the warranty period, no cost for parts replacement shall be charged.
3. During the service warranty period, products sent overseas shall be charged basic repair expenses. The buyer shall present the warranty card issued by our Company and negotiate with the repair and maintenance shop. Reasonable fees shall be charged to the buyer after consideration of such factors as the number of pieces to be repaired, actual state of the screwdrivers and approximate duration of usage and work load.
4. During the service warranty period, users shall present warranty cards for requesting repair of malfunctioning products. Failure to present a complete warranty card shall be considered as expiration of the card and non-entitlement to free warranty service. Repair and maintenance in such a case would allow distributors to charge the user cost of replaced parts and all repair expenses based on conditions set by the Company.
5. Beyond the dates specified in the warranty card, all repairs of products conducted anywhere in the world shall be charged actual material and repair costs. More importantly, the Company's distributors, overseas distributors and overseas branches shall handle repair and maintenance work of all Kilews Electric Screwdriver products, including those sold by OEM-brand companies. The Company shall uphold honest client service and practical attitude to provide after-sales service to its clients.

We welcome buyer's opinions on service quality. We shall give due importance to buyers in providing a sound and complete after-sales service. Thank you for using our product.

**Please save this original
warranty card.**