

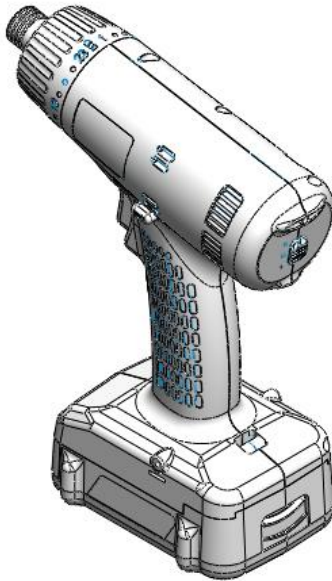

Semi-Automatic Cordless Brushless

Power Torque Screwdrivers Series

OPERATION AND MAINTENANCE MANUAL



SKC-PTS-120

SKC-PTS-80

SKC-PTS-50

KILEWS INDUSTRIAL CO., LTD.

<http://www.kilews.com>

Before you use the Cordless Screwdriver for the first time, it is essential to read and understand the manual completely. (Including the spare parts view)
The term “Cordless Screwdriver” in all of the warning listed below refers to your main operated appliance.

Icon Instructions

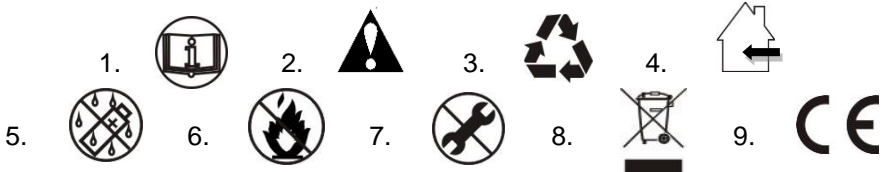

- | | |
|---|---|
| <ul style="list-style-type: none"> 1. Read instruction manual. 2. Observe caution and safety notes. 3. Recyclable. 4. For indoor use only. 5. Do not expose to wet or rain conditions. | <ul style="list-style-type: none"> 6. Do not operate in an explosive atmosphere. 7. Do not disassemble. 8. Forbid to throw away. 9. CE certification. |
|---|---|

Accessories

Item	Quantity	Unit
Manual	1	PCS
Guarantee Card	1	PCS
Waist Hook	1	PCS
Screw M3*0.5P*10LT	1	PCS
Socket Extension	1	PCS
Bit	2	PCS

Warning

Read all instructions and make sure the appearance of the device has no damage before you use it. Failure to follow all instructions listed below may result in electric shock fire and/or serious injury.

1. Keep the working area nice and clean.
 - 1.1 Mess and dark areas may cause of accidents.
 - 1.2 Keep the device away from rain or moisture to decrease the risk of electric shock or short-circuiting occurred.
2. Be alert to workplace safety
 - 2.1 Use the device under a well lit and clean environment.
 - 2.2 Keep children and other people away unless the person has been assigned for the task to avoid the danger of injury.
 - 2.3 Do not play around while the tool is being used to avoid the danger of distractions.
 - 2.4 Do not work with the device in potentially explosive environments in which there are inflammable liquids, gases or dusts. Electrical power tools create sparks, which can ignite dusts or fumes.
 - 2.5 Do not use the device if you are tired or under the influence of drugs, alcohol or medication.
3. When the devices are not being used, store them in a safe place.
4. Use a suitable device for the job will be safer at work and have a better result.
5. Always use a screwdriver that is intended for the task you are undertaking. Do not overload or use it improperly such as drilling or tapping.
6. Dress properly. Do not wear loose clothing or jewels while operating the tool to avoid the danger of trapping.
7. By using the device correctly, make sure to hold it firmly with two hands in place before starting the trigger.
8. When using the electrical power tool, take into account the auxiliary handle or waist hook is advantage of working conditions. On the contrary, the purposes of the waist hook or driver hook is convenient to put the device away and easier to keep it out of reach of children.
9. Look after either the device or the battery carefully and have any damaged parts repaired by an authorized or qualified shop. Always keep the tool nice and clean; pay attention on the machine grease which might ruin the tool.
10. Disconnect the plug from the power source after the charger has been used.
11. Take apart the battery from the device when it is not being used.
12. Use only the accessories that are detailed in the operating instructions. The use of others which are not recommended in the operating instructions may affect the functioning of the device. It could lead to an increased risk of personal injury as well.
13. Remain alert at all times and watch what you are doing during proceeding. Before operation, always check every part is in good condition and move freely in order to function properly.

14. This device only applies for metal screw bits designated with their dimensions and their shape. Do not recommend to countersink or force of loading on any material such as plastic and wooden.
15. The device does not apply for elastic or tensile load with washer on.
16. To prevent parts in gearbox from damage, replace the grease at least once for every year.
17. It is necessary for the operators to read and follow up all the operating instructions in this manual.
KILEWS is not responsible for any personal injury that might cause of disobeying the safety advices.

Function of Cordless Protection

- | | |
|------------------------------------|------------------------------|
| ■ Over electric current protection | ■ Prevent from low power |
| ■ Thermal Protector | ■ Stall protection |
| ■ Slow rotation protection | ■ Reverse control protection |
| ■ Battery Identification | ■ Sleeping mode |

Warning

 **Do not attempt to repair or disassemble this cordless screwdriver, the warranty will be considered void.**

1. This rechargeable screwdriver maintenance Make sure to remove the battery pack before maintaining or repairing the device by a qualified technician.
2. Do not attempt to disassemble or reassemble the device at will which may result in poor performance or danger of injury, the warranty applies only to initial package.
3. Do not repair the device with other than genuine KILEWS replacement parts may result in poor performance or danger of injury, the warranty will be considered void.
4. The temperature between 0° C ~35° C would be an ideal condition of carrying out the tasks on the device.

Operating Instructions

1. Charge the battery in the charging station before first use to make sure operates at its highest capacity. To ensure operators against injuries, release the forward/reverse lever as arrow showing below into a center position to have trigger locked before start or disassemble the device.

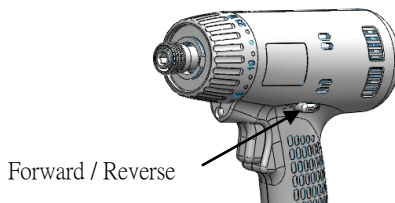

- 2.1 Below illustration is showing the process of correct install & disassemble the rechargeable battery. The beep sound comes along with a flash while the screwdriver is supplied genuine battery installation. It could be operated once the battery has been identified.
- 2.2 Too slow to install the battery may cause error identification so the beep sound and flash would be continuing. In order to function properly, re-assembling it as below process again.

Insert Battery Steps

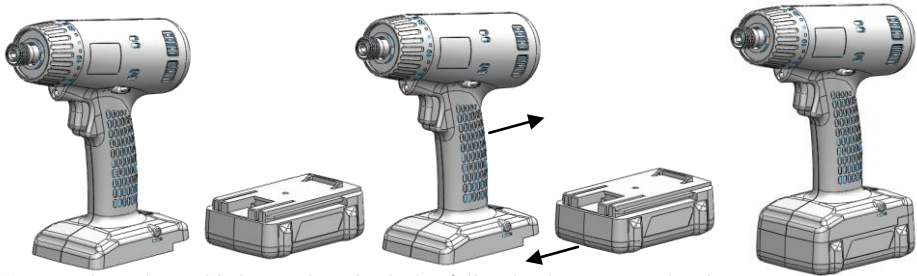

- (1) Insert the rechargeable battery into the device follow by the arrow as showing.
- (2) Assembled completely.

Remove Battery Steps

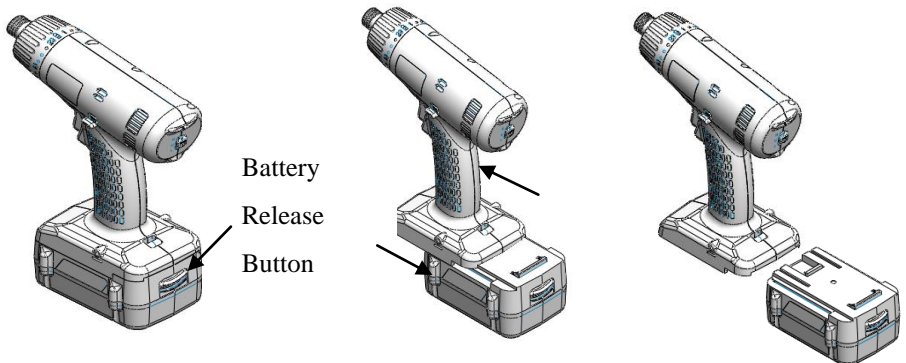

- (1) Press the release button and take it out of the device.
- (2) Follow the arrow direction.
- (3) Removed completely.

Function / Operating Introduction

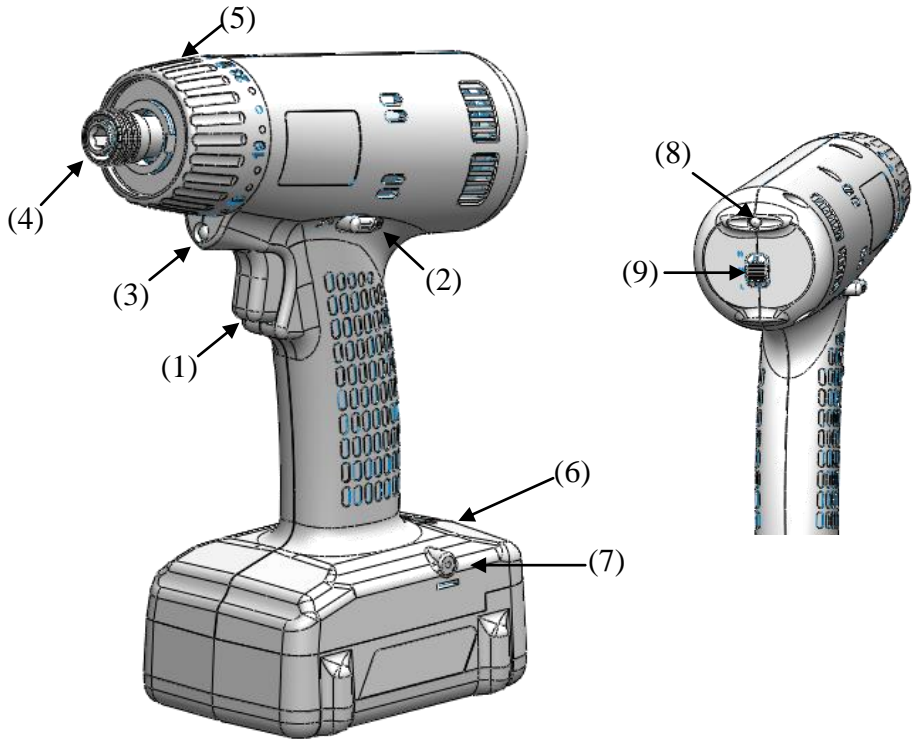

Function Name Table

No.	Description	No.	Description
(1)	Trigger switch	(6)	Wrist strap hole
(2)	Forward/Reverse lever	(7)	S waist hook
(3)	LED light	(8)	Indication light
(4)	Bit sleeve	(9)	Speed adjustment
(5)	Torque adjustment		

Manual / Function

1. SEMI-AUTO cordless screwdriver

Taking the finger off the lever whenever the device reaches the setting torque while comes along with clutch DA-DA-DA sound. Continue running after screws are tightened up which is more than 8~10 clutch noisy may result in overloaded and cause damage of the task.

(1) Trigger switch



When the start switch is pressed into 1/3 trip, the front end light will be turn on for operation.

When it reach from half trip to full trip , the screwdriver begin to start impact from low speed to maximum speed until the default timer is reched for each H/M/L torque level.

Screwdriver will stop by release the start switch or the H/M/L default operation time is reached.

For safety and power consumption consideration, screwdriver will automatic stop after 30 seconds operation.

(2) Forward / Reverse switch

When push the Forward/Reverse switch to the right. According to the symbol  on the switch, the screwdriver rotates clockwise and tightens the screws. When push the switch to  the screwdriver will rotate anti clockwise and loosen the screw. When the screwdriver is idle, set the Forward/Reverse switch in the middle.

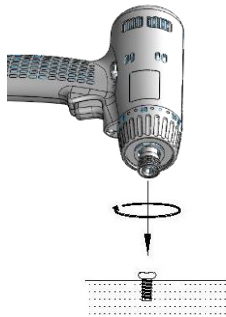

Forward (screw)

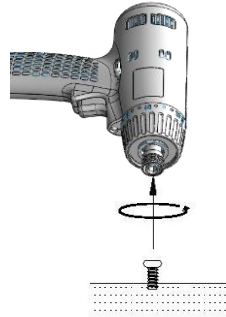

Reverse (unscrew)

(3) LED light

While press the trigger, the LED lights up automatically to assist the job to be done; on the contrary, it will be off once the trigger has been released.

(4) Bit sleeve

Switch the screw bit and compatibility, pull the head of the type B screwdriver, and install the bit according to the diagram below, after installing the bit please also install the W type cap and push it in following the arrow indicated on the diagram below on Diagram 2.

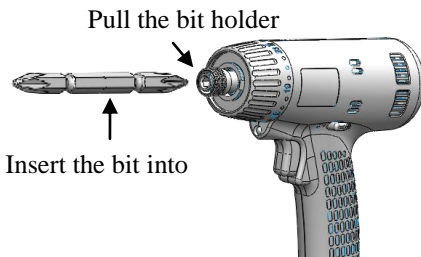

Diagram 1

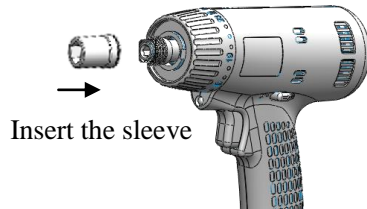



Diagram 2

(5) External torque adjustment

The purpose of the torque adjustment is to have the torque level changed from level 1~23; each level has different torque, follow the direction as below showing while the figure value gets bigger means for more torque.

Direction of rotation 

Torque adjustment ring portrayed Digital larger torque follow larger.

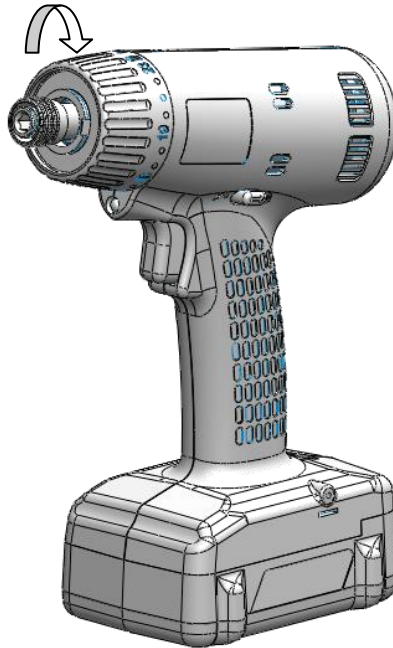

(6) Hole for wrist band

Enable to install the wrist band which is more convenient and safer for users.

(7)Waist hook

The waist hook allows users to carry the device easily by attaching it to their work belt.

(8) Functional light and the status indicator

Whenever the remaining power in the rechargeable battery is fewer than 20%, the tool is still alive but with red flash lights on. Once the remaining power is towards 10% or even fewer it may result in poor performance with the continuing red lights on.

(9)H/M/L Switch

With three level speed control design for applying to different application. Be sure that choice the suitable speed level and torque scale for different material and joint before tightening.

The suggested maximum torque scale for each speed level show as below:

Function Speed adjustment	Operation Speed Ratio	Suggested MAX Torque Scale
Hi	100%	1~23 檔+Max 檔
Mid	75%	1~17 檔
Lo	50%	1~11 檔

2. Warring beep sound

- (1) Screwdriver stops along with three warring beep occurs while the motor speed is lower than 1000 rpm.
- (2) PCB temperature detector preventing the screwdriver overheated; it stops along with three warring beep occurs while the PCB temperature is over 70°C.
- (3) Restarting the screwdriver which dismissing from a safety mood may come along with three beep sounds.

Other Cautions

1. The best condition of using the tool is under 8 hours a day, do not over loaded.
2. Do not attempt to repair or disassemble this cordless screwdriver without authorization. Always have the device serviced by assigned factory or qualified person in order to have the warranty effective continually.
3. KILEWS is not responsible for any poor performance or damage caused by customers own modification of the tool.
4. It is necessary for the management to have individual operators read and follow up all instructions in this manual. Do not attempt to repair or disassemble this cordless screwdriver themselves.
5. Chemicals, Acetone, Benzene, Alcohol, Thinner, Ketone, trichloroethylene, etc shall not be in contact with the surface of the screwdriver in order to prevent chemical damage.
6. Please follow instruction carefully and do not drop or shock the screwdriver.
7. This product allows you to adjust freely (-) and (+) to decrease and increase torque. Different models will deliver different level of torque, when the torque is adjusted to the limit the switch will not be able to turn, please do not force it or it will be damaged. High frequency of using this power tool might cause overheating, please have the tool to be cool down properly.
8. Not allow to turn the Hi/Lo switch during operation in order to cause system malt-function.
9. The device will not be able to function again once the OK/NG indicator/signal is not turn off yet.
10. When adjusting the torque, for safety purpose should stop the screwdriver completely and set the switch to neutral position. It could prevent the user from turning the tool on accidentally.
11. During operation, the switch has been changed accidentally that the device will enable its self-protecting mode which is power off. Re-start the tool when this happen.
12. Each operational torque setting, using time and frequency may result in different level of wear and tear, at higher torque setting and use extensively could accelerate the wearing down of tool. After one month, the torque is getting reduce gradually at the rate of 2~3% or 3~5 %(max torque). The longer use of the device, torque reduction will become stable and the users could measure the torque by a tester on a regular time schedule to check if the torque power still meets the criteria.
13. The torque range of SKC-PTS-120/80/50 must be measured by the KILEWS torque meter KTM-4B-25.
14. Kilews cordless screwdriver torque output is generated by clutch machnism, and it is applicable to ISO 6789.

Description of battery and charger

1. KILEWS SKC-LB series of batteries as options to fit in the device; you may consult with local agent based on your task requirement.
2. The use of other than genuine KILEWS batteries or screwdrivers can't be active due to the build-in protection system enforce no charging.
3. SKC-P120W charger with LED on is recommended.

Specifications

MODEL		SKC-PTS-120	SKC-PTS-80	SKC-PTS-50
INPUT VOLTAGE(DC)		DC 18V		
TORQUE	(N.m)	6~12	4~8	1.5~5
Torque accuracy (%)		±10%		
Torque Adjustment		Toque adjusting cap		
Unloaded Speed R.P.M. n0: (r/min) ±10%	HI	700→0	1200→0	2200→0
	Mid	500→0	900→0	1600→0
	LO	350→0	600→0	1100→0
Screw size (mm)	Machine screw	≤6	5.0~6.0	4.0~5.0
weight (Kg)		1.0kg(w/o battery)		
length (mm)		188 mm * 182mm (L*H w/o battery)		
Applicable battery		SKC-LB Series		
Applicable charger station		SKC-P120W SKC-P80W SKC-80W		
Applicable Bit type				

Bits Code ~ W: square B: Hex 6.35mm

Accessory ~ B I T no. : NO.3# apply to 3.0~4.0mm

CAUTION 

SAVE THE INSTRUCTIONS

DO NOT DESTROY

零件編號	排插位置	零件編號	排插圖示	排插位置
11	11-1	14		14-1
12	12-1			
13	13-1			

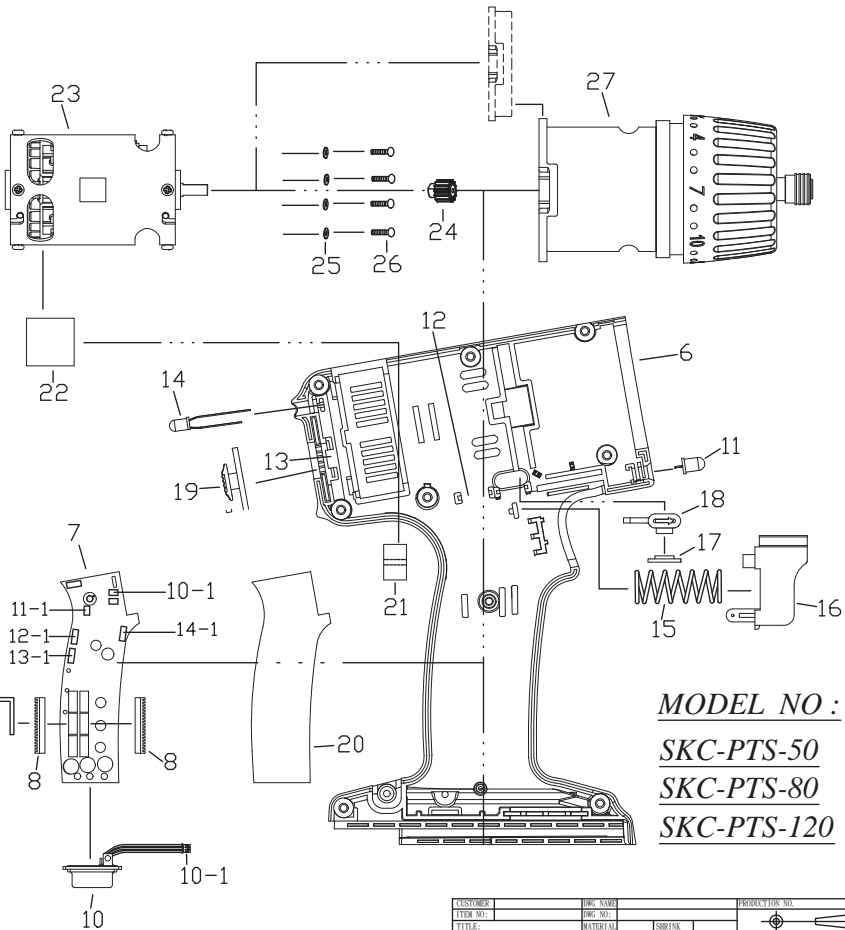
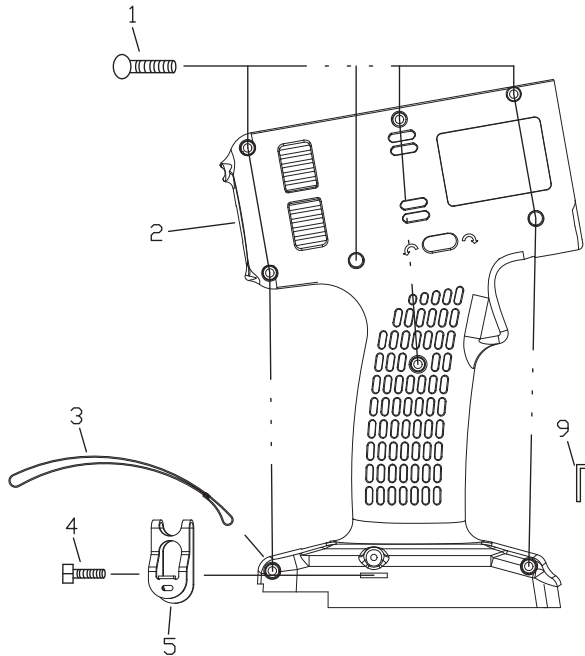

MODEL NO :
SKC-PTS-50
SKC-PTS-80
SKC-PTS-120

CUSTOMER	ORG. NAME	PROJECT NO.	
ITER. NO.	DATE	UNIT	
TITLE	MATERIAL	SIZE	
DES. BY	DATE	UNIT	SCALE
CHKD. BY	DATE	UNIT	SCALE
APPD. BY	DATE	UNIT	SCALE

KILEWS INDUSTRIAL CO., LTD.

NO	PARTS NO	PARTS NAME-E	PARTS NAME-C	Q'ty	NO	PARTS NO	PARTS NAME-E	PARTS NAME-C	Q'ty
1	CH20527	Screw	螺絲	9	19	CI50216-1	HI-LO Switch	高低速切換推板	1
2	CAB00003	Housing-Upside	上蓋	1	20	W10200	Insulating Washer	PC絕緣墊片 30*102*0.2	1
3	R481874	Wrist band	手腕帶	1	21	W10200-2	Insulating Washer	PC絕緣墊片 固定線夾	1
4	CH20525	Screw	螺絲	1	22	W10200-1	Insulating Washer	PC絕緣墊片 30*30	1
5	CJ20014	Waist hook	S腰帶吊鉤	1	23	MO00001	Motor Assembly PTS-120/80	馬達成品 PTS-120/80	1
6	CBB00003	Housing-Underside	下蓋	1		MO00002	Motor Assembly PTS-50	馬達成品 PTS-50	1
7	EG31513	PCB	控制機板	1	24	M11333	Drive Pinion PTS-120	馬達主齒PTS-120	1
8	E32205	HEAT SINK	散熱片	2		M11332	Drive Pinion PTS-80	馬達主齒PTS-80	1
9	W50109-3	CLAMP	散熱片夾簧	1		M11334	Drive Pinion PTS-50	馬達主齒PTS-50	1
10	EG31504-3	Power Module	電源模組半成品	1	25	CH20301-10	WASHER	華司	4
11	N15017-1	LED Light	LED照明燈半成品	1	26	CH20161-2	Screw	螺絲	4
12	EG31439-1	F/R Switching Element PCB	正反轉機板半成品	1	27	GZPTS12000-1B	Gear Housing for PTS-120B	齒輪箱成品 SKC-PTS-120B	1
13	EG31440-1	Speed adjustment PCB	高低速機板半成品	1		GZPTS12000-2B	Gear Housing for PTS-120B9.5	齒輪箱成品 SKC-PTS-120B9.5	1
14	E33111	Red LED	LED 發光二極體 紅光	1		GZPTS12000-1W	Gear Housing for PTS-120W	齒輪箱成品 SKC-PTS-120W	1
15	CK28033	Trigger Spring	壓板彈簧	1		GZPTS8000-1B	Gear Housing for PTS-80B	齒輪箱成品 SKC-PTS-80B	1
16	CC70014F	Trigger Assembly	手按開關半成品	1		GZPTS8000-2B	Gear Housing for PTS-80B9.5	齒輪箱成品 SKC-PTS-80B9.5	1
17	E63231-1	Forward/Reverse Spring	正反切換桿彈片	1		GZPTS8000-1W	Gear Housing for PTS-80W	齒輪箱成品 SKC-PTS-80LW	1
18	CI50218-1	Forward/Reverse Lever PTS-120	正反切換桿半成品 (黑色) PTS-120	1		GZPTS5000-1B	Gear Housing for PTS-50B	齒輪箱成品 SKC-PTS-50B	1
	CI50218-2	Forward/Reverse Lever PTS-80	正反切換桿半成品 (藍色) PTS-80	1		GZPTS5000-2B	Gear Housing for PTS-50B9.5	齒輪箱成品 SKC-PTS-50B9.5	1
	CI50218-3	Forward/Reverse Lever PTS-50	正反切換桿半成品 (棕色) PTS-50	1		GZPTS5000-1W	Gear Housing for PTS-50W	齒輪箱成品 SKC-PTS-50W	1