

AUTOMATIC SCREW FEEDER

KFA-0820A (VACUUM TYPE)

INSTRUCTION MANUAL

(ENGLISH)

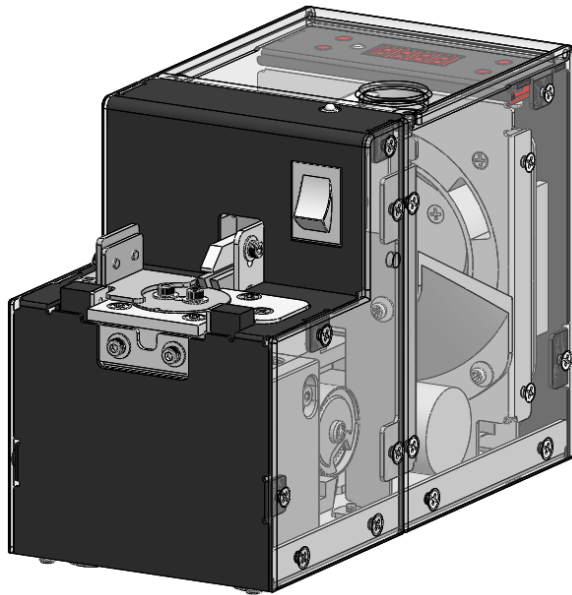

Please read this manual thoroughly, before operating the unit and retain it for future reference.

**Patented in China, Taiwan, Japan & Korea.
Imitation of product will be caused prosecution.**

Y2F147-1-001

SAFETY INSTRUCTIONS

PLEASE NOTE FOLLOWING CONDITIONS BEFORE USING KILEWS KFA-0820

- ◎ For a normal performance, please install this machine on a flat and stable working table, do not slant or pad, otherwise machine function might be affected.
- ◎ Turn off the power switch and unplug the AC adaptor when this machine is not being used for a period of time.
- ◎ To avoid damage and malfunction, use the AC adaptor supplied with this machine only.
- ◎ Keep the surface of the rail groove clean and free from dust and oil. Failure to keep the rail groove clean could result in damage to the machine.
- ◎ The applied screws must be clean without grease or dust, and screw size is within specified range as machine rail.
- ◎ Handle screws on rails with care, do not use excess force to remove them or the rails may be damaged.
- ◎ When scooping chamber is turning, do not put fingers or objects other than screws into the chamber.
- ◎ Do not turn ON the power switch before the rails are set properly for operation.
- ◎ In case of malfunction during operation, please turn off the power and unplug the AC adaptor. Contact your supplier at once.

Whenever this machine requires service, please contact your supplier for assistance, or go to our website & e-mail us your contact detail and requirement, we will respond ASAP.

CONTENTS

CHECK BEFORE OPERATION	1
CHECK THE SCREW SIZE	1
FUNCTIONS WITH ADJUSTING HOLES ON HOUSING AND PCB ..	1
ADJUSTMENT	2
ADJUST THE RAIL ASSEMBLY	2
DISMANTLE THE RAIL ASSEMBLY	2
ADJUST THE WIDTH OF RAIL ASSMEBLY	5
INSERT THE RAIL ASSEMBLY	7
ADJUST THE HOLDING PLATE.....	9
ADJUST THE FEEDING STRUCTURE	10
ADJSUT THE SENSOR FUNCTION	11
ADJUST THE BRUSH	12
OPERATION METHOD	13
LOAD SCREWS INTO CHAMBER	13
DISPLAY PANEL OPERATION.....	14
MAINTENANCE & TROUBLE SHOOTING	17
MAINTENANCE & CLEANING	18
INTERNATIONAL WARRANTY CONDITIONS	19



CHECK BEFORE OPERATING

CHECK THE SCREW SIZE

Measure the size precisely on each part of applied screw with a caliper.

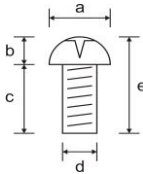
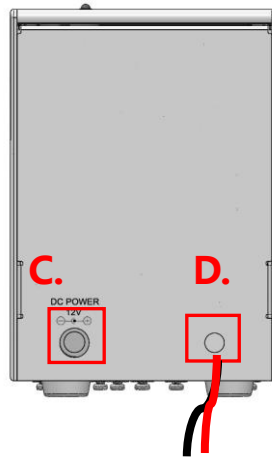
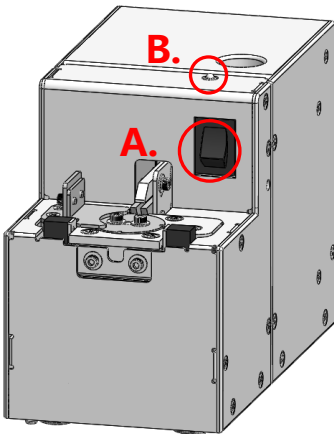

Table a.

a	Dia. of Screw Head
b	Height of Screw Head
c	Screw Length
d	Dia. of Screw Bolt.
e	Screw Total Length

FUNCTIONS WITH ADJUSTING HOLES ON HOUSING AND PCB



- | | | |
|----|------------|-------------------------|
| A. | POWER | POWER SWITCH |
| B. | INDICATION | LED INDICATION LIGHT |
| C. | DC POWER | DC POWER HOLE |
| D. | SIGNAL | GROUNDING & SIGNAL HOLE |

ADJUSTMENT

After checking the screw size, it needs to adjust all related parts according to the screw size for the first use.

ADJUST THE RAIL ASSEMBLY

DISMANTLE THE RAIL ASSEMBLY

1. Remove the fixing screws of guide assembly, dismantle the guide assembly.

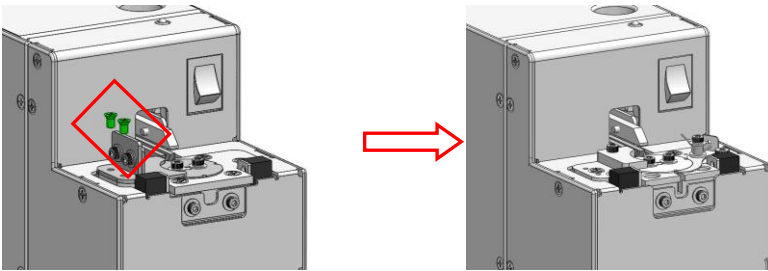

2. Remove the fixing screws (8pcs) of front housing, and take off the front housing.

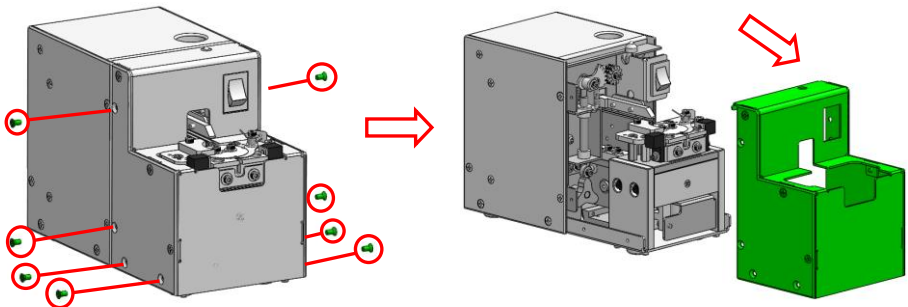

3. Dismantle the fixing screws*4 of feeding structure, and take it off.

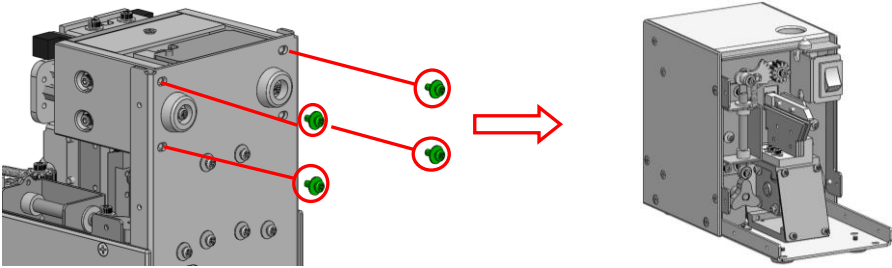

4. Facing the machine, loosen the screw of lock gate, open the lock gate upward and fasten screw.

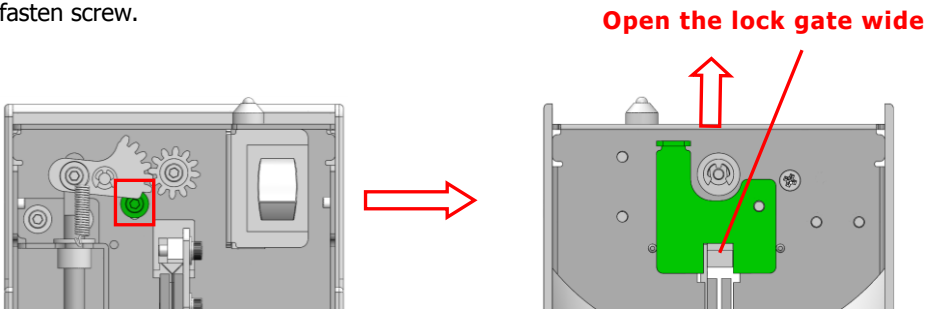

5. Remove the fixing screws of rail assembly

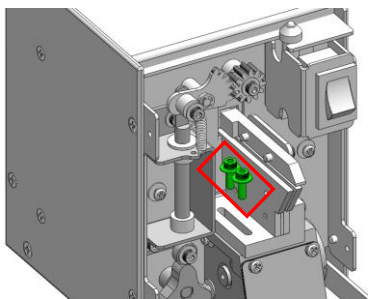

6. Draw out the rail assembly from the machine.

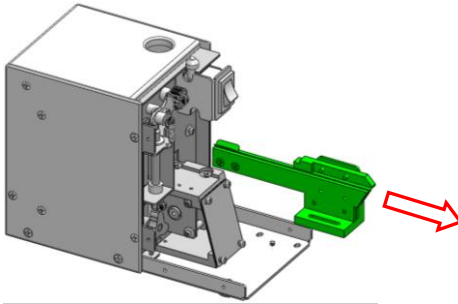

※ NOTE THE FOLLOWING WHEN MAKING ABOVE ADJUSTMENT ※

- a. Before dismantle the rail assembly, please confirm the lock gate status is open.
- b. Dismantle the guide assembly first, and then take off the front housing.
- c. Loosen the fixing screw of lock gate only, do not remove the screw.

ADJUST THE WIDTH OF RAIL ASSEMBLY

1. Remove the fixing screw on the rear end of rail assembly.

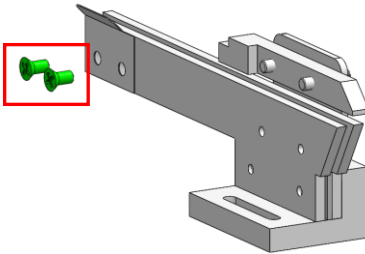

2. Remove the fixing screw on the front end of side of rail assembly, take off the tooling plate.

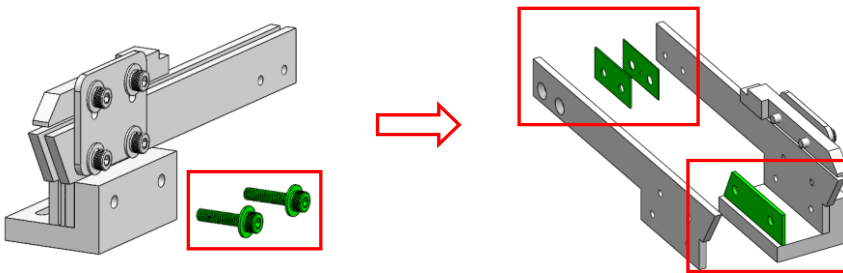

3. According to Table b, insert the suitable tooling plate into the rail groove for the width required and tighten the screw of step 2.

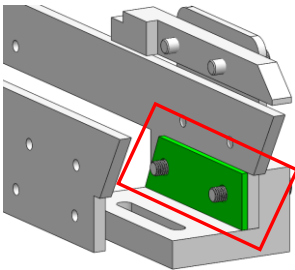

4. Insert the tooling plate in the rear end of rail according to Table b, fasten the screw of step 1.

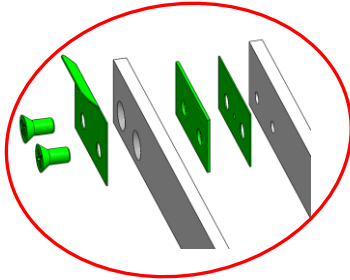

※ **COMBINATION OF THE THICKNESS FOR REFERENCE** ※ **Table b**

Dia. of Screw Bolt (d) mm	Accessory-Tooling Plate (Rear) mm
0.8	1.0mm
1.0	1.2mm
1.2	1.4mm
1.4	1.6mm
1.6	1.8mm
2.0	2.2mm

5. After width adjustment of the rail assembly, place a screw into the groove and slide it up and down to both sides, to check whether the movement is smoothly.

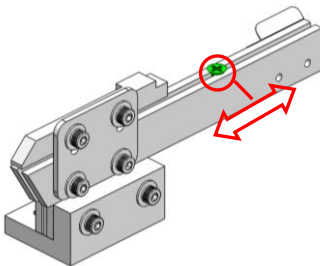

※ **NOTE THE FOLLOWING WHEN MAKING ABOVE ADJUSTMENT** ※

- Please must keep the width of rail from the beginning to the end uniformly.
- When adjusting the width of front rail assembly, the screw of step 2 must be fastened.

INSERT THE RAIL ASSEMBLY

1. After the width adjustment of rail assembly, insert it into machine, and then fasten screw.

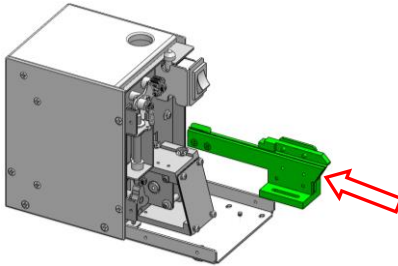

2. Install the feeding structure, and then fasten screw.

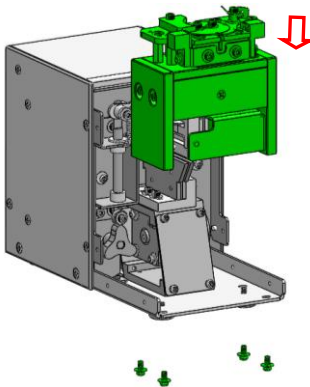

3. Loosen the fixing screw of rail assembly, keep 0.2~0.5mm open space between the front end of rail assembly to circled plate, and then fasten screw.

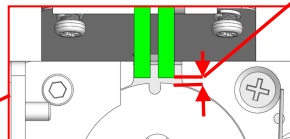
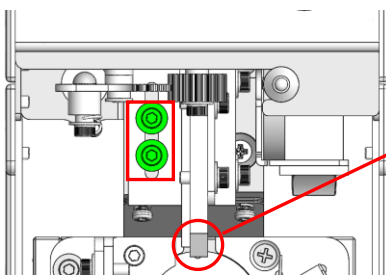

0.2~0.5mm

4. Set the lock gate, keep 0.2~0.5mm open space between gate to rail assembly.

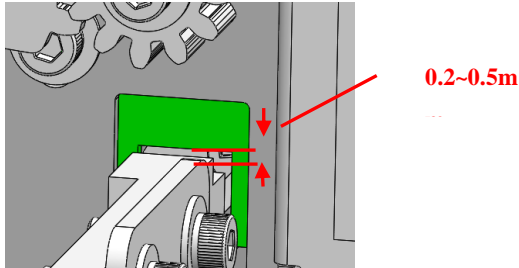

※ **NOTE THE FOLLOWING WHEN MAKING ABOVE ADJUSTMENT** ※

- When inserting the rail assembly, it must to keep 0.2~0.5mm open space from the circled plate.
- Keep 0.2~0.5mm open space between the lock gate to rail assembly.
- Make sure the front and rear of feeding structure to avoid installing it reversely.

ADJUST THE HOLDING PLATE

1. Loosen the screw of fixing holding plate.

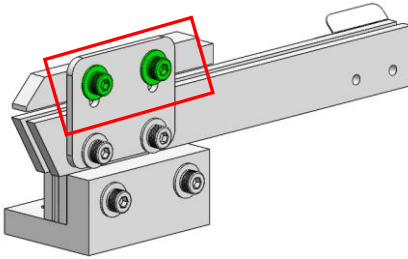

2. Adjust the height of holding plate by tooling plate, and fasten the screw of step 1.

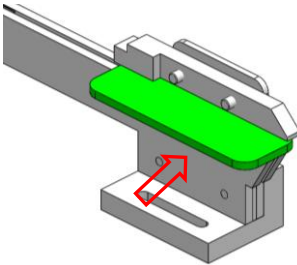

3. Place some screws into the groove and slide them up and down, to check whether the movement is smoothly.

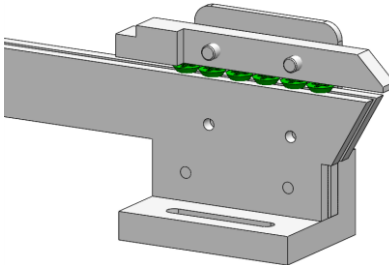

※ **NOTE THE FOLLOWING WHEN MAKING ABOVE ADJUSTMENT** ※

a. When adjusting the holding plate, the screw of step 1 must be tightened.

ADJUST THE FEEDING STRUCTURE

1. Loosen the fixing screw of feeding structure

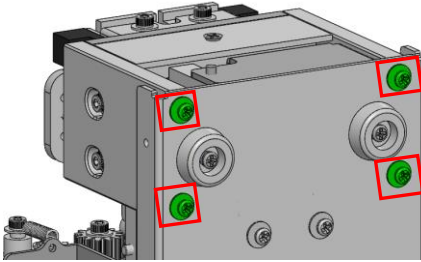

2. Adjust the groove of circled plate to the middle of rail, and then fasten the screws of step 1.

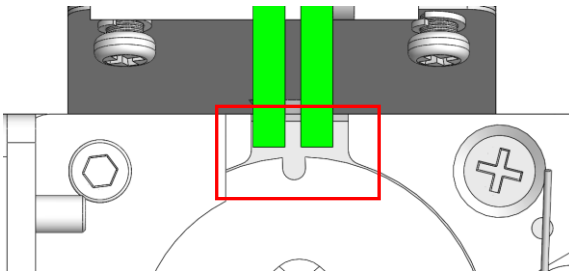

※ NOTE THE FOLLOWING WHEN MAKING ABOVE ADJUSTMENT ※

- After adjustment, operate the machine to make sure the groove of circled plate to the middle of rail when running.
- The screw of feeding structure must fasten completely to avoid the screws falling into machine.

ADJUST SENSOR FUNCTION

1. Loosen the fixing screw of sensor fixing plate

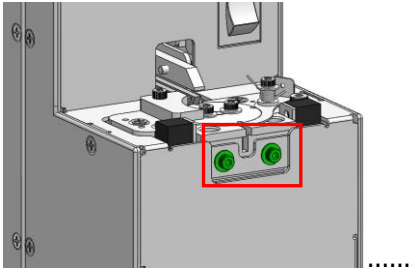

2. Make sure to cover half of the hole, and then fasten the screw of step 1.

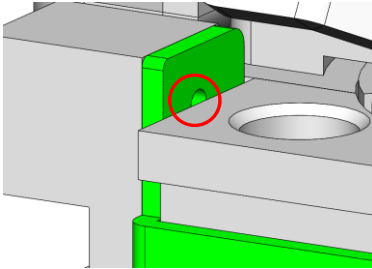

※ NOTE THE FOLLOWING WHEN MAKING ABOVE ADJUSTMENT ※

- a. Make sure to cover half of the hole, and do adjustment to ensure the sensor function no problem.

ADJUST THE BRUSH

1. Swing the brush to stay almost horizontal, loosen screw on the side of brush bracket.

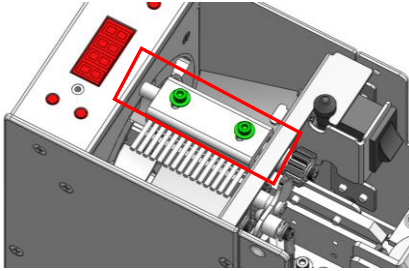

2. Place 5~8 screws into the rail groove close to the holding plate rear end, loosen 2 screws on the side of the brush bracket, swing the brush down and adjust the height, the brush just touch the screw heads slightly, and tighten the screws after adjustment.

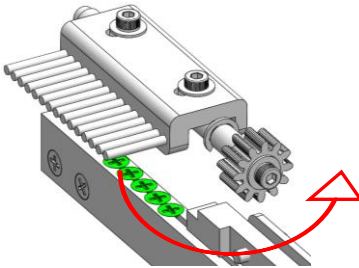

3. When fix the brush position, keep suitable space for the Front Plate and Fixing Plate.

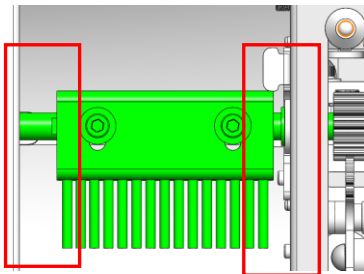

※ NOTE THE FOLLOWING WHEN MAKING ABOVE ADJUSTMENT ※

- After adjustment of the height of the brush, swing the brush by hand to make sure the movement properly and smoothly.
- The brush length is inconsistently, please ensure the brush match rail when replace it.

OPERATION METHOD

LOAD SCREWS INTO CHAMBER

Turn off the power first, and open the Top Cover Box. Ensure the screws are loaded without foreign materials, pour in screws until they come up to 1~2mm below the top on both sides of the rails.

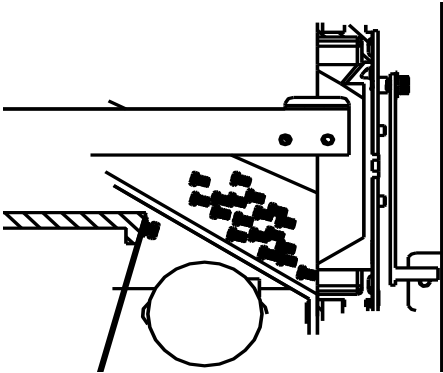

All objects other than applied screw are deemed as foreign material which should be removed first; or it will affect the performance of this machine.

OPERATION MANUAL

A. DISPLAY PANEL

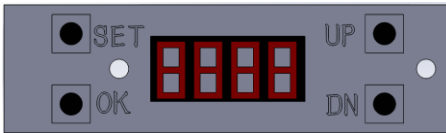

B. FUNCTIONS OF KEYS ON PANEL

SET : SET FUNCTION

OK : CONFIRM (COUNTER FUNCTION)

UP : INCREASE VALUE (ADDEND KEY)

DOWN : DECREASE VALUE (SUBTRAHEND KEY)

C. DESCRIPTON OF FUNCTION

1. Total counting status : Press OK to switch the status for counting value automatically or setting counting.

2. Default setting : Either in operation or standby status, press the SET+OK in 3 seconds that LED displays flicker 3 seconds with beep to remind the system turn back default setting.

3. SET FUNCTION

3.1 Either in operation or standby status, **press SET 1 time in 3 seconds to configure counting setting**, LED monitor shows flicker,

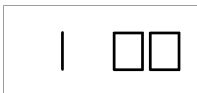

press UP or DN to increase or decrease the numbers

(Default setting is 00, and the setting range is 00-99) , With or without pressing any key in 3 seconds, setting will be completed with buzzer alert.

※Note : If it is not into setting counting status, please press OK to switch the status.

3.2 Either in operation or standby status, **press SET 2 times to configure increasing or decreasing progressively**, LED monitor shows flicker,

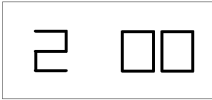

, 00 is increasing progressively, 01 is decreasing

progressively, press UP or DN to increase or decrease the numbers (Default setting is 00, with or without pressing any key in 3 seconds, setting will be completed with buzzer alert.

※Note : If it is not into setting counting status, please press OK to switch the status.

3.3 Either in operation or standby status, **press SET 3 times to configure**

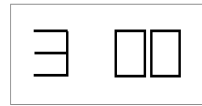

precaution buzzer, LED monitor shows flicker, 00 to turn on buzzer and 01 to turn off buzzer, press UP or DN to adjust (Default setting is 00), with or without pressing any key in 3 seconds, setting will be completed with buzzer alert.

3.4 Either in operation or standby status, **press SET 4 times to configure extension time for vibration**, LED monitor shows flicker,

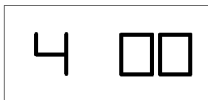

press UP or DN to adjust extension time (**Default setting value depends on screw type, and setting range is 01-12 seconds**) , with or without pressing any key in 3 seconds, setting will be completed with buzzer alert.

3.5 Either in operation or standby status, **press SET 5 times to configure**



vibration strength, LED monitor shows flicker, press UP or DN to configure vibration strength (Default setting value depends on screw type, and setting range is 01~10, there are total 10 steps from 5v-10v, every 0.5v is a step) with or without pressing any key in 3 seconds, setting will be completed with buzzer alert.

3.6 Either in operation or standby status, **press SET 6 times to configure**



extension time for roller, LED monitor shows flicker,

press UP or DN to adjust extension time (**Default setting value depends on screw type, and setting range is 01-12 seconds**) , with or without pressing any key in 3 seconds, setting will be completed with buzzer alert.

3.7 Either in operation or standby status, **press SET 7 times to configure**

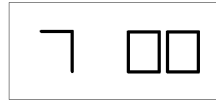

vibration strength, LED monitor shows flicker,

press UP or DN to configure vibration strength (Default setting value depends on screw type, and setting range is 01~10, there are total 10 steps 5v-10v, every 0.5v is a step) , with or without pressing any key in 3 seconds, setting will be completed with buzzer alert.

3.8 Either in operation or standby status, **press SET 8 times to configure**

motor rotation speed, LED monitor shows flicker,



press UP or DN to configure motor rotation speed for screw feeder (Default setting value depends on screw type, and setting range is 01~10) , with or without pressing any key in 3 seconds, setting will be completed with buzzer alert.

3.9 Either in operation or standby status, **press SET 9 times to configure**

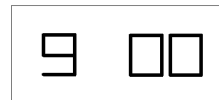

changeover vibration, LED monitor shows flicker,

00 is rotate in clockwise and 01 to rotate in counter-clockwise, press UP or DN to configure vibration changeover (Default setting is 00) , with or without pressing any key in 3 seconds, setting will be completed with buzzer alert.

MAINTENANCE & TROUBLE SHOOTING

TURN OFF THE POWER BEFORE REPAIR

PROBLEM	PROBABLE CAUSES	SOLUTION
No operating or with Buzzer sound when Power turn ON	There is no power supplied or the cord loosened	Check the power supply and cord
	The screw chamber is overloaded with too many screws	Remove some screw out to a proper level
	Problem with power switch, motor or PCB	Replace the faulty switch, motor or PCB
	Screw has fallen down in the machine	Remove the screw dropped
	Sensor position wrong	Adjust the sensor position
	Sensor is blocked	Remove the block
Roller stopped	Roller motor malfunction	Replace the roller motor
	Roller has got stuck or gears have been stripped	Remove the stuck or replace new gear
No screw comes out from Rail	Width of rail groove is incorrect	Adjust the width of rail groove
	Screw with abnormal posture stops halfway in the lock gate	Adjust the height of brush
	Lock gate too small	Adjust the lock gate
	Screw is caught at holding plate abnormally	Remove the misplaced screw, and adjust the height of holding plate.
	Vibrated motor malfunction	Replace the vibrated motor
No signal output	Main board burn out or connector loosened	Check if the output voltage is 5V by electric meter. 1. If yes, check the connector 2. If no, replace the main board

MAINTENANCE & CLEANING

Turn off the POWER before performing maintenance and cleaning.

CLEANING AND MAINTENANCE THE BRUSH Using the dry cotton to wipe the brush to remove the dust. Swing the brush by hand and adjust the height of the brush to make the brush in touch with screw heads. Replace the brush when brush hair is too worn and cannot wipe down screws in an improper position.

CLEANING AND MAINTENANCE THE RAIL Withdraw the rail assembly, clean the rail groove and top of the rail (area for screws flow) with a clean thin cotton cloth soaked with alcohol or benzene. Use the Allen Key to check if the screws for the parts of rail assembly are fastened.

INTERIOR CLEANING After cleaning the rail assembly, take out any screw or foreign material inside of machine, and clean whole interior parts, walls particularly the motor, PCB and gear to prevent effecting against machine functions.

OPTIONAL PARTS :

Please use genuine parts to ensure products quality and avoid influences caused against performance of this machine.

REMARK :

When using screw of special types or other than specified, please consult our distributors.

WARRANTY CARD

The warranty is valid for 12 months from purchase date (based on 8 working hours a day). Please contact your supplier during the warranty period for repair or maintenance.

❖ NOTE:

1. The service cost shall be considered as chargeable if the failure/cost was induced by any of the following conditions:

- Failure due to improper handling or un-authorized modification.
- Failure has nothing to do with the original design of the machine.
- Labor and parts cost to replace the consumable parts (brush, motor, rail assembly, etc.).

2. The WARRANTY will be void under any of the following conditions:

- Failure arising from a case or an accident beyond one's control or Act of God.
- It has been modified, altered and/ or repaired by an unauthorized dealer, purchaser or third party.
- The serial number, warranty card has been altered, de-faced and /or removed.
- Failing to use genuine parts sold or recommended by the Company.

3. Under this warranty, the company only provides service at any time during normal business hours. Should emergency service is required outside normal business hours, and such service if available will be provided with a charge on a per call rate basis.

4. The warranty is not transferable without the consent of the Company .

WARRANTY CARD

CUSTOMER :	
TELEPHONE :	
ADDRESS :	
PURCHASE DATE :	
DISTRIBUTOR :	
MODEL NAME	AUTOMATIC SCREW FEEDER (VACUUM TYPE)
MODEL NO.	
SERIAL NO.	
SCREW SIZE	0.8~2.0mm
SWITCHING ADAPTOR	DC IN 12V
MEASUREMENT	MACHINE : 160 (L) * 82 (W) *112 (H) mm
	EACH CARTON :250 (L) *180 (W) *120 (H) mm
WEIGHT	N.W 1.53kgs
	G.W 2.0kgs

REMARK :